

meet **pat**®

Where innovation flows.

Permanent Refill Station
Wall Mount PM-RS-03-WM

INFORMATION BOOKLET



Safe drinking
water for all

Refill + Refre

meetpat®

WELCOME

We began meetpat to change the way people think about public water stations, and in doing so we believe we can drive change for generations to come.

meetpat acknowledge and pay respects to Wiradjuri peoples, Elders and Country whose land we operate our business. We also acknowledge that Aboriginal and Torres Strait Islander peoples hold extensive knowledge about connections to water, which has been practiced for thousands of generations.

Congratulations on purchasing a world class, smart water station.

Fundamentally, we care about delivering safe, clean water and ensuring positive public adoption of water stations. We design and manufacture products with the safety of you, the user, foremost in mind. In addition, we ask that you exercise a degree of care when using any meetpat product.

Please follow this information booklet to effectively install your product.

All recommendations within this document should be used as a guide only. Users and installers should seek suitable assistance to ensure products comply with all standards and are safe for use. meetpat are constantly evolving and updating products to ensure that they are designed and manufactured to the highest possible standard. Manufacturing and product parts are subject to change without notice. Please ensure you follow the supplied current guidelines when installing and servicing your product.

DISCLAIMER & SAFETY



INSTALLER NOTE.

Adhere to the risks/cautions outlined by meetpat, along with the regulations outlined by the local governing body.





RISK/CAUTION	DISCLAIMER	CHECK
Structural Integrity of Mounting Surface	Meetpat takes no responsibility for the structural integrity of the mounting surface chosen and recommends consultation with an engineer or other suitable parties prior to mounting.	
Appropriately Qualified Installer	Products with a fixed supply line and drainage connection must be installed by a licensed plumber. Meetpat products must be installed in accordance with the provisions of AS/NZS3500.1 and AS/NZS3500.2 and any relevant local regulations. Installations not complying, may void the product warranty and cause reduced performance.	
Water Supply Line Temperature	Minimum operating temperature is 1 Degree Celsius. Maximum operation temperature is 38 Degrees Celsius. Outside of this temperature range may cause operational issues and damage to the unit. This will also void warranty for parts.	
External Surface Temperature/ Location	Meetpat products are suitable for a large range of outdoor locations (including direct sun), however certain installation locations will optimise user experience. Consideration should be given to the best placement of the unit. If exposed to direct sun in extreme temperature environments for extended periods of time, water and surface temperatures may become high enough to cause a potential risk to users. Meetpat provides thermal protection on the pipework of all units.	
Supply Line Pressure	Maximum working pressure is 500kpa Minimum working pressure is 120kpa Pressures outside of this range may result in operational issues/ and or damage to the unit. Supply line pressure outside of this range will void warranty.	
Potability	Check source water quality prior to installation. Please note that this system is intended for use with clean and safe potable drinking water only. It is important that the water is microbiologically safe and of known quality before using the system. Do not use with water that may be contaminated or of unknown quality without proper disinfection.	
Accessibility	Meetpat takes no responsibility for the suitability of any install location, clearance for traffic, pedestrians or other clearance requirements. Meetpat recommends that the chosen location(s) are reviewed for compliance with OH&S, local regulations and guidelines, to ensure compliance.	

DISCLAIMER & SAFETY

RISK/CAUTION	DISCLAIMER	CHECK
Infrared Sensor	Touch free sensor has limitations activating on some surface materials and finishes. May include but not limited to; matte black, glass and highly reflective materials.	
Dog Bowl including Drainage Pit	The dog bowl mechanism is not to be submerged in water. Ensure each Dog Bowl is installed with adequate drainage and in accordance with this installation guide. Incorrect or poor installation without appropriate drainage will void the product warranty.	
Maintenance	Regular maintenance and cleaning will avoid premature degrading of the product. Failure to install unit correctly or conduct preventive maintenance, may result in voiding the product warranty. E.g. continuously running tap may cause rapid degradation of drainage areas and is not a product material fault.	
Drainage	Periodically check all drainage, including Dog Bowl with drainage pit. The installation location and environmental factors will impact the maintenance scheduling.	
Electrical Wires	 Do not position products near live exposed electrical connections of wires.	



Ensure all personal protective equipment is used.
 Do not use power tools or installation equipment in an unsafe manner.
 After installation, keep these instructions for future reference.
 Products are heavy to install. Use appropriate number of people and equipment.

Wear PPE suitable for the installation type	   	Ear Protection Eye Protection Appropriate Footwear Cut Resistant Gloves
Use Correct Tools		Always use the correct tools which are in good working condition, during the installation and maintenance of any product. Proper use of tools is your responsibility.
Moving Parts		Water stations are made up of moving and sliding parts. Ensure to keep all body parts, loose clothing and cables away from these areas.

Make sure you are fully prepared before getting started!

Read through all of these instructions and safety precautions before beginning the installation or any service.

Following these steps will help keep everyone safe and injury-free.

CONTENTS

Accessibility Guidelines 7

Set Up

Refill Station Overview 9

 Wall mount Set Up 11

 Register Water Station 13

Installation Guide

Installation & Plumbing | Refill Station Wall Mounted..... 15

 Fitting Access Panel 18

 Fitting the Filter 20

 Turn On Solar Lighting..... 21

Tall Extension Kit 23

 Installation 25

Fitting Panels 27

Maintenance & Servicing

Refill Station Overview & Scheduling 30

 Panel Removal & Replacement 32

 Filter Install & Replacement 33

 Mesh Filter Clean & Replacement 34

 Sensor Tap Battery Replacement 35

Cleaning Instructions 36

 Troubleshooting 37

 Warranty 38

 Contact 39

Accessibility and installation guidelines.

We designed meetpat's advanced modular system to make drinking water accessible for everyone.

We are proud to supply world leading accessibility and DDA compliance features, including one-handed operation

While the product itself is important, inclusivity also flows through to the installation. The water station location and infrastructure will ensure maximum user engagement. In these guidelines we have outlined what is required to ensure your installation follows the same accessibility of the water station.

ACCESSIBILITY GUIDELINES | WALL MOUNTED

Refer to governing body for accessibility compliance.

Before and during installation consideration is required to ensure there is sufficient room around the unit for wheelchair and pedestrian access.

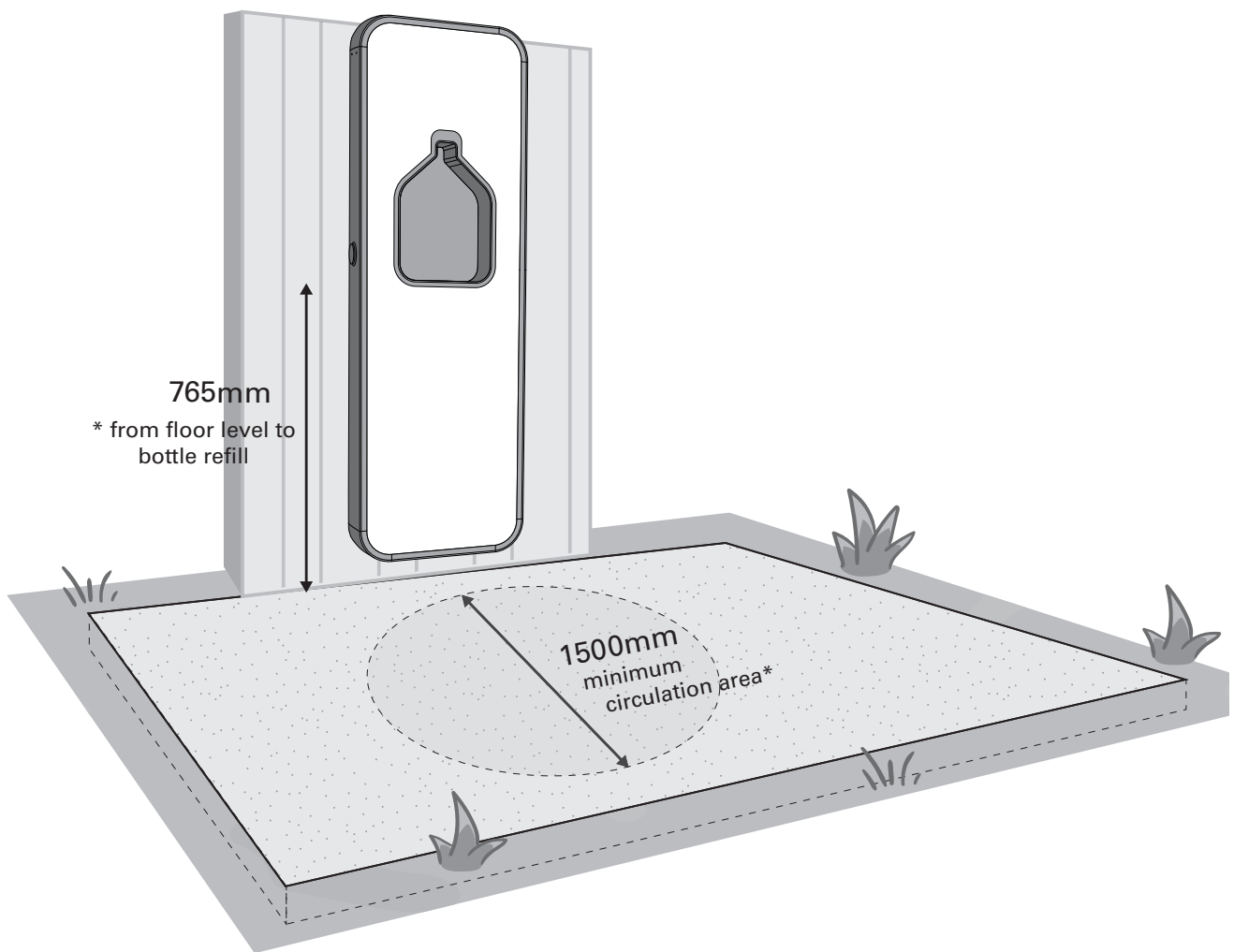

ADDITIONAL SAFEGUARDS FOR TEMPERATURE

Meetpat products are suitable for a large range of outdoor locations (including direct sun), however certain installation locations will optimise user experience. Consideration should be given to the best placement of the unit. If exposed to direct sun in extreme temperature environments for extended periods of time, water and surface temperatures may become high enough to cause a potential risk to users. Meetpat provides thermal protection on the pipework of all units.

MIN operating temp is 1 degree Celsius | MAX operating temp is 38 degree Celsius

Accessibility guidelines supplied within this booklet should be taken as a guide only. Sites and site details will vary for each installation. In order to ensure the meetpat water station remains compliant. Please refer to the current disability standards in your region.

Product Overview | Set Up

Wall Mounted PM-RS-03-WM

This water station is manufactured using stainless steel and powdercoated aluminium. With a lead free plumbing system and anti-bacterial bottle refill dispenser. This water station comes with fixings to secure your water station to a wall or solid structure.

OVERVIEW | REFILL STATION | PARTS SUPPLIED

A Refill Station

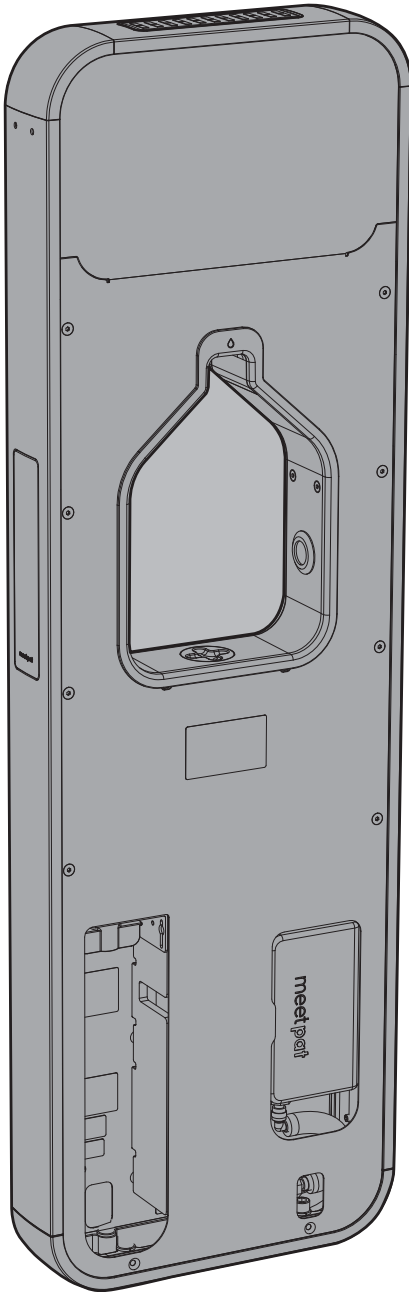

B Graphic Panel x1

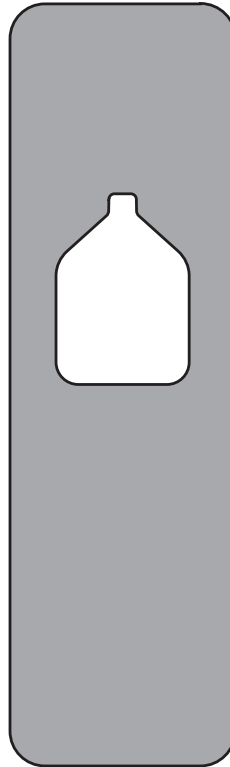

C Stand off brackets x6

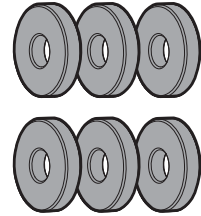

*supplied inside the water station

ACCESSORIES purchase separately

1 Tall Extension Kit
PM-TK-01

2 Water Filter
AX-FS-01
AX-FR-01
AX-FL-01

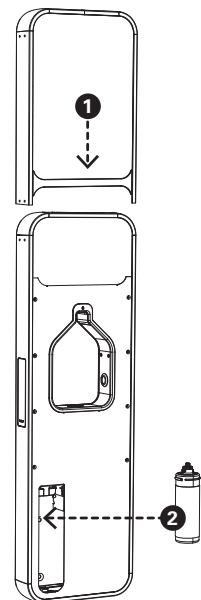

OVERVIEW | WALL MOUNT SET UP

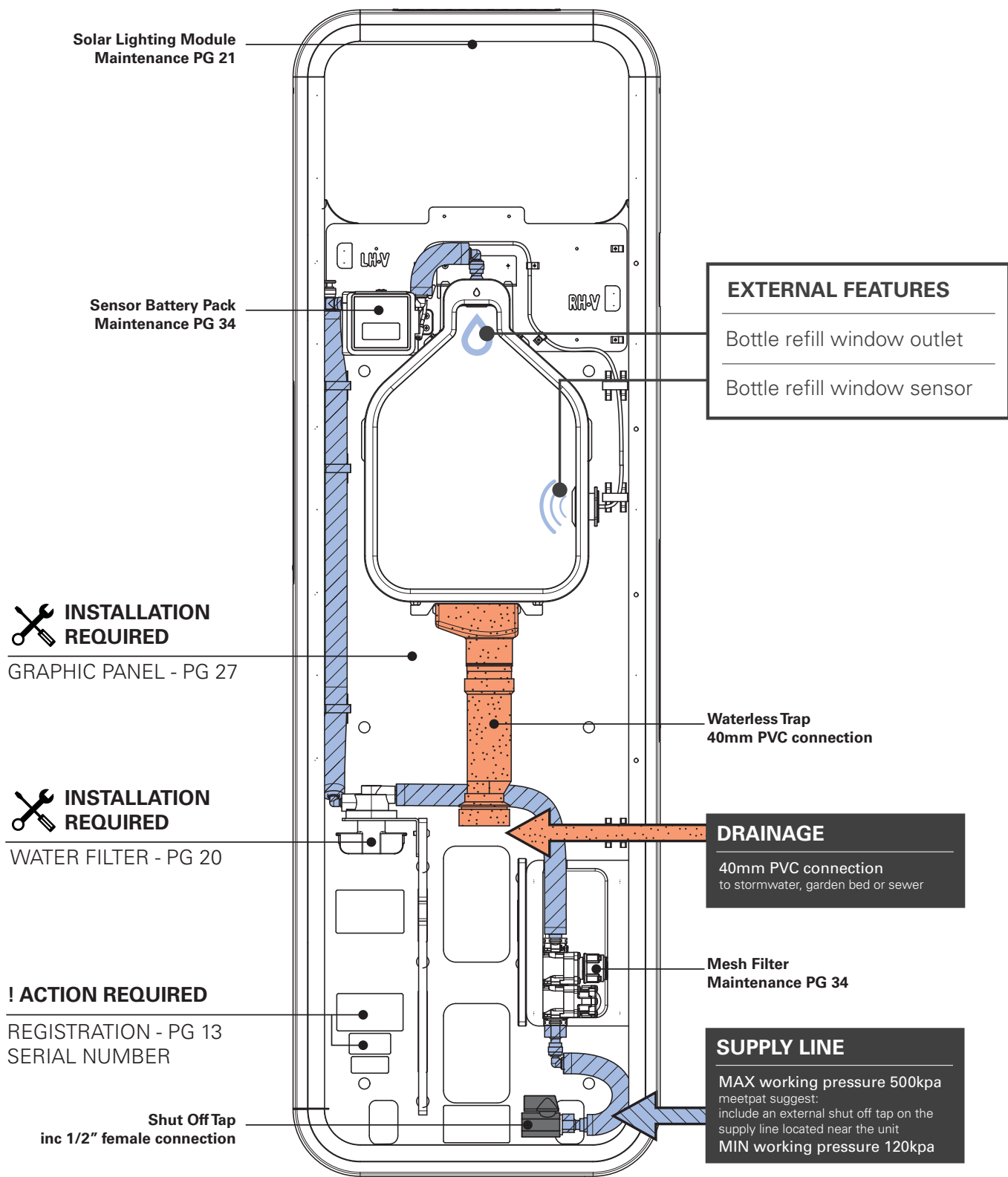

MIN operating temp is 1 degree Celsius
MAX operating temp is 38 degree Celsius

Supply line and drainage connection must be installed by a licensed plumber

OVERVIEW | WALL MOUNT SET UP

Set up your water station prior to commencing the installation.
Ensure all items removed during the process are set aside and reattached after install.

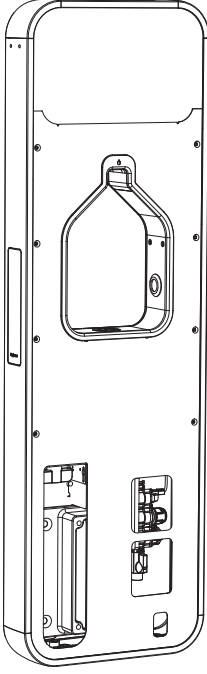
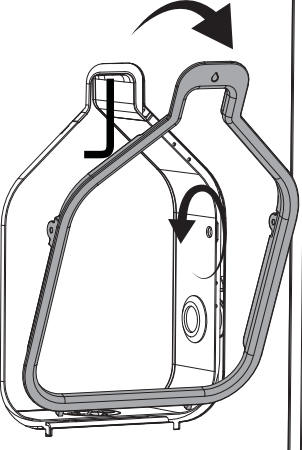
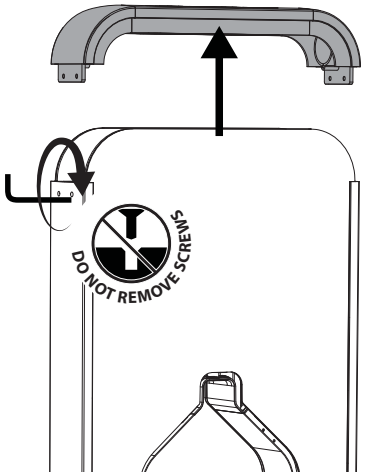
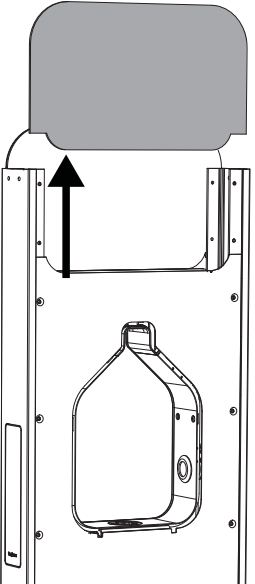
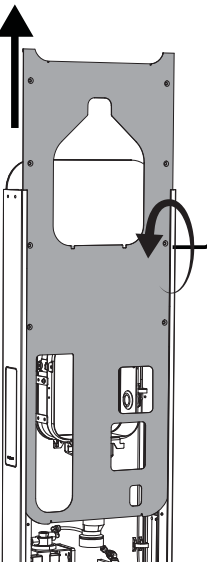
<p>1</p> <p>Remove the refill station from box.</p> 	<p>2</p> <p>Remove bottle refill surround.</p> <p>4mm Allen Key 3x Anti-clockwise Remove Completely</p> 	<p>3</p> <p>Remove solar lighting module.</p> <p>4mm Allen Key 4x Clock-wise Loosen Only 3TURNS ONLY</p> 
<p>4</p> <p>Remove the lighting backing panel.</p> 	<p>5</p> <p>Remove the access panel.</p> <p>4mm Allen Key 8x Anti-clockwise Remove Completely</p> 	<p>FINISHED</p> <p>MOVE TO REGISTERING YOUR WATER STATION & ACCESSORIES (IF PURCHASED)</p>

INITIAL INSTALL | REGISTER WATER STATION

RECORD YOUR INFORMATION HERE

If you are undertaking the initial install of this water station.

Locate and record the Serial Number & Registration Code here.

Any future access to this information requires removal of front panel.

SERIAL NUMBER: _____

REGISTRATION CODE: _____

DESCRIPTION: _____

1 Location for **PM-RS-03 | XS-RS-03** (Permanent & Semi-Portable)

2

Scan QR code | Visit web page

app.meetpat.com/active

! REQUIRES INTERNET CONNECTION. IF UNAVAILABLE RECORD THE NUMBER/CODE TO ACTIVATE LATER

3 Using information located on the label. Fill in the details and follow the prompts to register your product.

! REGISTER ALL ACCESSORIES PURCHASED BEFORE PROCEEDING TO INSTALLING THE REFILL STATION

DRINKING FOUNTAIN

DOG BOWL & PIT

TALL EXTENSION KIT

ACCESSORIES ARE NOT COMPATIBLE WITH ALL REFILL STATION MODELS

Water station | Installation Guide

Wall Mounted PM-RS-03-WM

Once assembly has been completed, you can proceed to installing the water station. This is connection to the water supply and drainage, along with making sure the water station is mounted to a suitable and structure.

Any product with a fixed supply line and drainage connection must be installed by a licensed plumber.

PLUMBING & INSTALLATION | WALL MOUNT

SOLAR LIGHTING
Turn On / Checking -
 During water station installation check & turn on solar lighting
REFER PG 21

Connect the water station by bringing plumbing in through the back of the unit.
 Fix the water station using suitable fasteners. This will depend on the wall type you are mounting to.
 Connect the plumbing internally. Then turn on the water and check for leaks

WATERLESS TRAP
Threaded 40mm PVC connection - Drains to stormwater, agi-pipe to garden bed or sewer

INLINE CONNECTION
Threaded 1/2" male connection

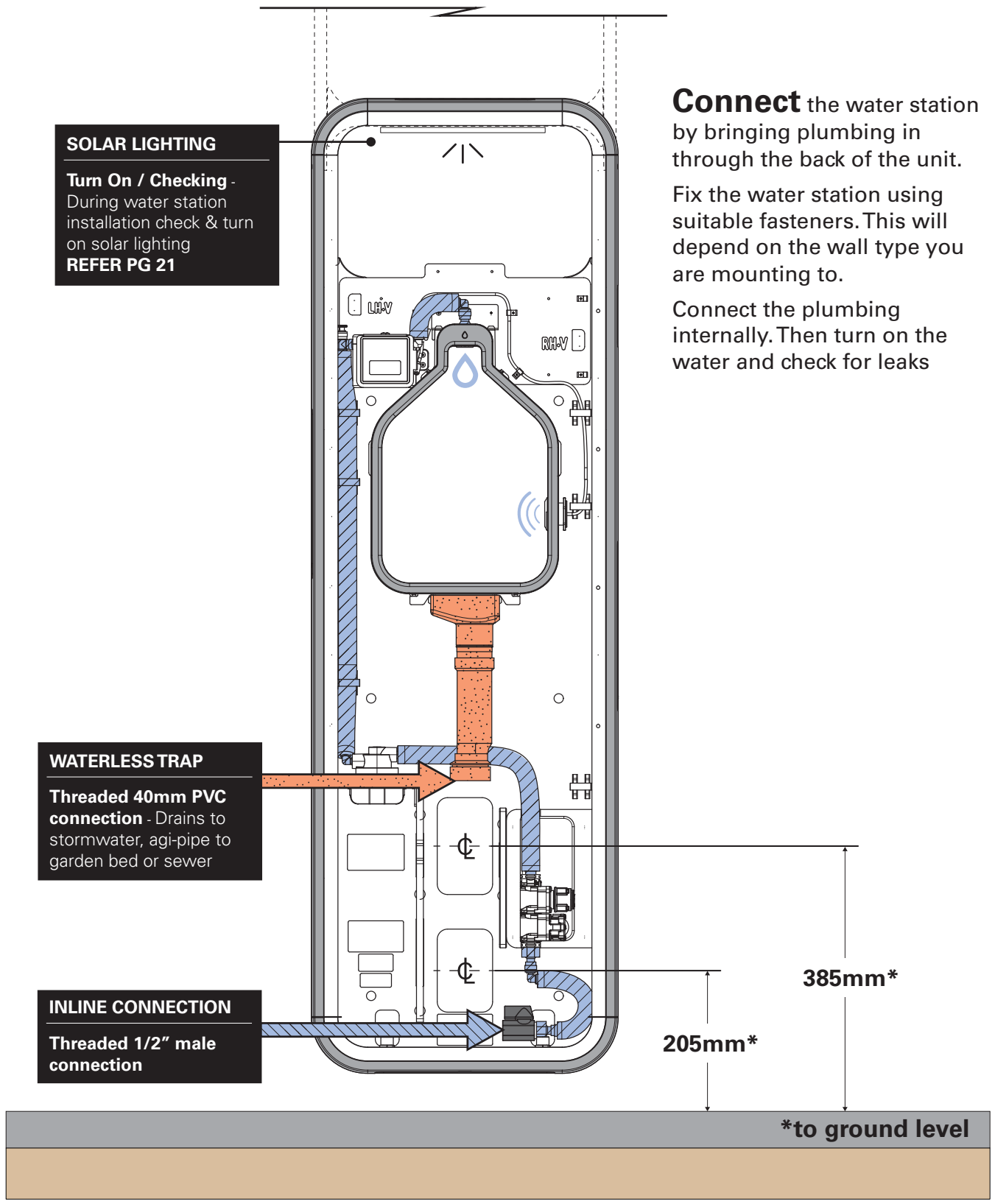

PLUMBING & INSTALLATION | WALL MOUNT

Front View

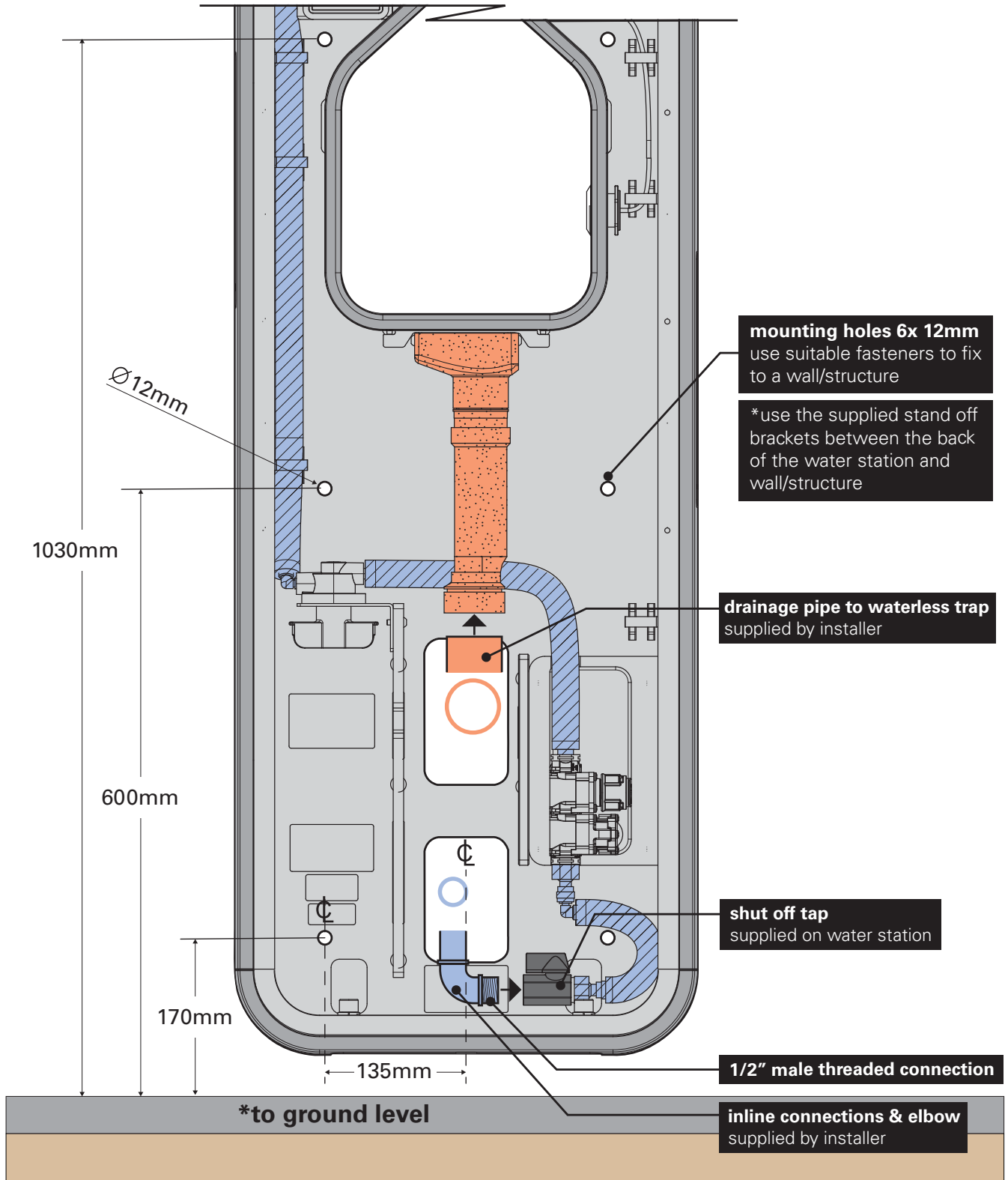

INSTALLATION | FITTING ACCESS PANEL

Once the water station is installed, refit the access panel (removed during the initial set up). Then proceed to the Final Fittings.



IMPORTANT

PRIOR TO REFITTING YOUR ACCESS PANEL

ENSURE YOU HAVE COMPLETED ASSEMBLY, SET UP AND INSTALLATION.

- Water station assembled
- Drainage connected
- Water supply line installed
- Water station functioning correctly
- Water flushed through unit to remove air bubbles and debris
- Water on and checked for leaks
- Check inlet pressure is below 500kpa

1 Slide down the access panel. (previously removed)

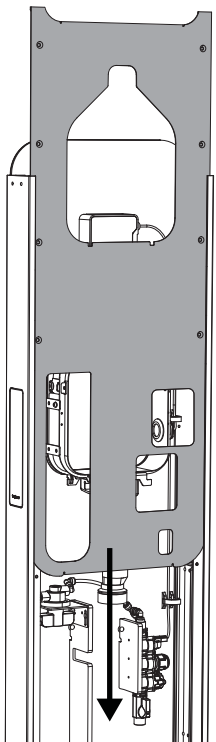

CAUTION
HANDLE PANEL WITH CARE TO AVOID INJURY TO SELF OR DAMAGE TO CABLES

2

4mm Allen Key 8x Screws Clockwise

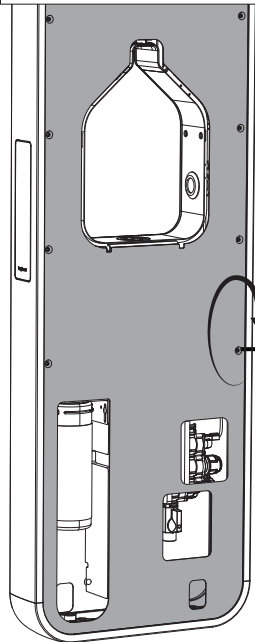

Refit the access panel. Using the previously removed screws.

DO YOU HAVE A TALL EXTENSION KIT?
Continue to follow this installation guide for fitting instructions and solar lighting set up.

FINISHED
MOVE TO FINAL FITTINGS

Proceed to page 19

Water station | Final Fittings

Wall Mounted PM-RS-03-WM

Once assembly and installation have been completed, you can proceed to the final fittings guide. Fitting off all the accessories and parts ensures your water station is complete and ready for use.

FITTING THE FILTER | READY FOR USE



ALWAYS TURN OFF WATER SUPPLY

DE-PRESSURISE THE WATER STATION BY ACTIVATING ALL SENSOR BUTTONS

1

Ensure the front graphics panel is removed. Refer panel removal

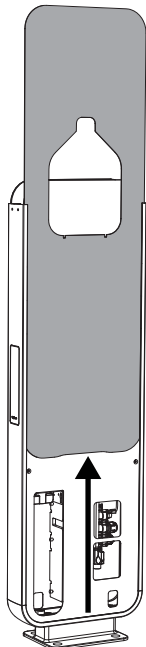

2

Locate the shut off valve. Turn off water supply.

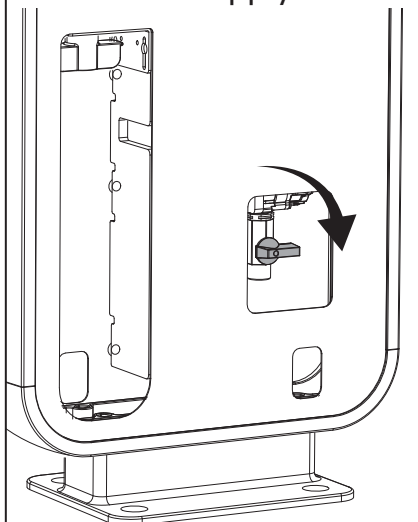

3

Release all pressure from the water station.

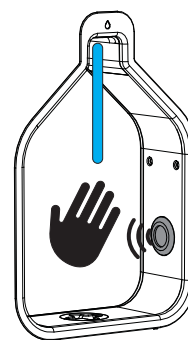
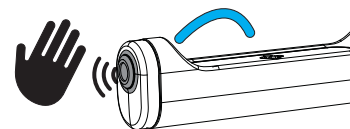

Activate all the sensor buttons

4

Locate filter plug *or used filter if installed. Turn Clockwise to completely remove.

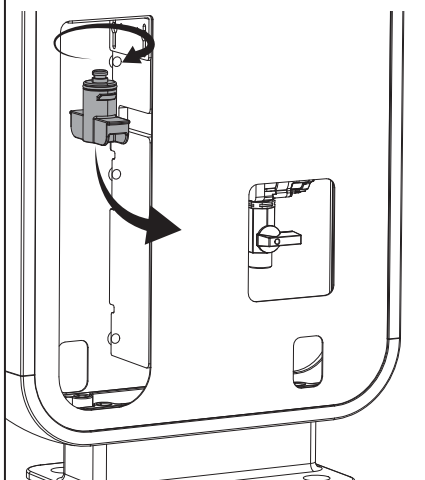

5

Install **new** filter. Turn Anti-clockwise to fit. Hand tighten.

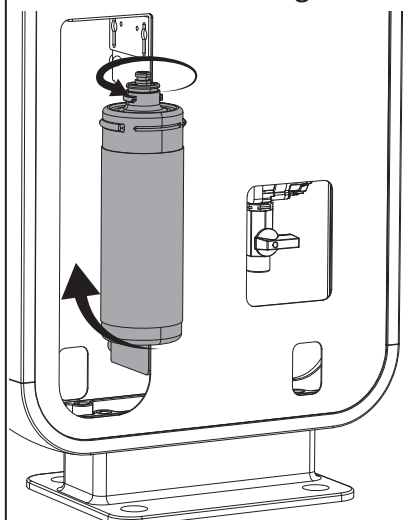

6

Open valve to turn on water supply.

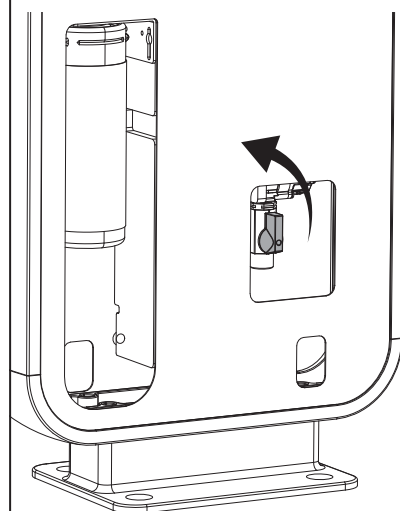

IMPORTANT

ACTIVATE ALL SENSOR BUTTONS TO FLUSH WATER & CHECK FOR LEAKS.

Refer troubleshooting to resolve any problems.

TURN ON SOLAR LIGHTING | READY FOR USE

Water stations are fitted with a solar lighting module, which should be turned on and checked during the installation process.

1 **Locate and detach** the solar lighting module



I look like this.

Solar Panel

 **THIS SYSTEM IS FITTED WITH AN AUTOMATIC LOW LIGHT SENSOR**
IT WILL ONLY ILLUMINATE DURING LOW LIGHT (NIGHTTIME) OR WHEN THE SOLAR PANEL IS FULLY COVERED.

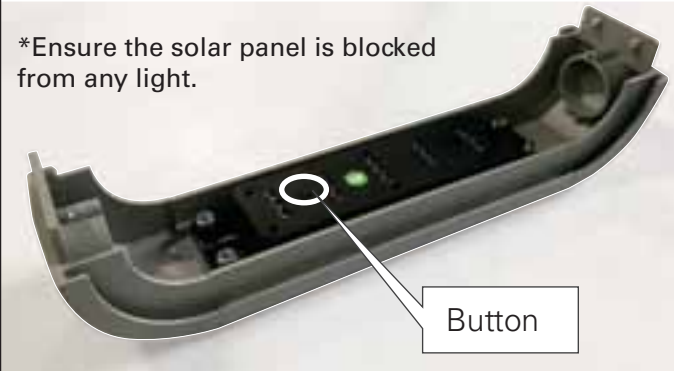

2 Flip the module upside-down and place on soft/scratch free surface*

*Ensure the solar panel is blocked from any light.



Button

3 **Locate Button**
Press button to cycle through modes to the preferred setting.

-  **1 - Dim**
-  **2 - Full**
-  **3 - Off**

 **NOTE**
SOLARTOPS ARE SUPPLIED SWITCHED OFF

4 **ENSURE SOLAR LIGHTING MODULE IS NOW TURNED ON (LIGHTS ON)**



! TEST - LIFT UP TOP ASSEMBLY
The lights should turn off when the Solar Panel is uncovered. (Unless you are operating in low light (night time).

 **FINISHED**
MOVE TO INSTALLING THE TALL EXTENSION KIT OR FITTING YOUR PANELS

 **LIGHTING NOT WORKING?**
TRY CHARGING THE SOLAR PANEL.
Place in direct sunlight for 2 hours and retry.
Placement undercover, seasonal changes (summer/winter) may effect the ability to fully charge the lighting module with sufficient light.

Tall Extension Kit

meetpat accessories | PM-TK-01

meetpat Tall Extension Kit is compatible with permanent and semi-portable Bottle Refill Stations.

The kit is manufactured using powdercoated aluminium featuring polycarbonate graphics panels with antigraffiti protection.

OVERVIEW | TALL EXTENSION KIT | PARTS SUPPLIED

The Tall Extension Kit is not a stand alone product and must be installed to a permanent or semi-portable meetpat bottle refill station.

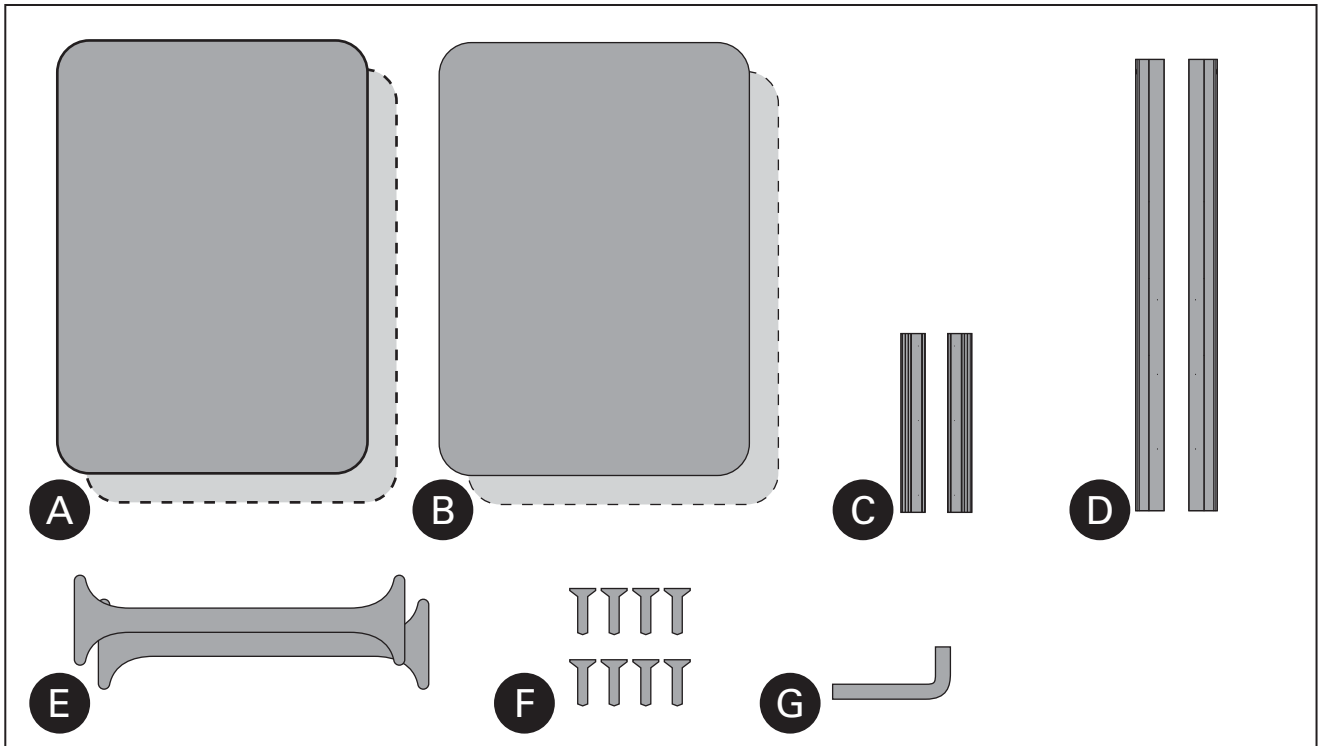

- A** 4mm Backing Panels
(Ground mount x2) (Wall mount x1)
- B** 2mm Graphics Panels
(Ground mount x2) (Wall mount x1)
- C** Bracing Sections (x2)
- D** Side Extrusions (x2)
- E** Panel Dividers (x2)
- F** Screw Sets (x2)
16x M6 x 12 button head screws
8x M8 x 12mm grub screws
- G** 4mm Allen Key

EXTERNAL FEATURES

- Solar lighting module (repositioned from the refill station.)
- Graphics panel

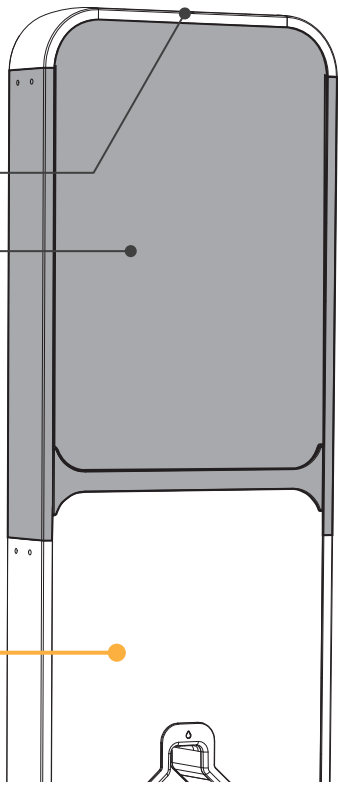

ENSURE ALL STEPS ARE COMPLETED PRIOR TO FIXING THE TALL EXTENSION KIT
Assemble the bottle refill station, drinking fountain kit(s), dog bowl and accessories.

INSTALLATION | TALL EXTENSION KIT

Complete the assembly and installation for the bottle refill station, as outlined in the information booklet. Ensure all items removed during this process are set aside for reattaching after the unit has been installed.

1 Slide down 2x Bracing Sections.

2

4mm Allen Key
4x Screws M8
Clockwise

CAUTION
ALWAYS FIX SCREWS INTERNALLY.
EXTERNALLY FITTING WILL INTERFERE
WITH THE INSTALLATION OF PANELS

3

4mm Allen Key
4x Screws M8
Clockwise

Slide down and screw fix 2x Side Extrusions.

4

4mm Allen Key
16x Screws M6
Clockwise

Secure in place with 16x screws

PRIOR TO FITTING THE PANELS
ENSURE YOU HAVE:

- Dog Bowl - **Installation Complete**
- Filter - **Installed**
- Solar Lighting - **Turned On**

FINISHED
PROCEED TO FITTING PANELS
THIS WILL FINALIZE YOUR REFILL STATION. READY FOR USE.







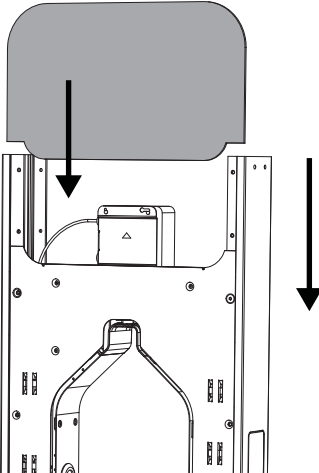
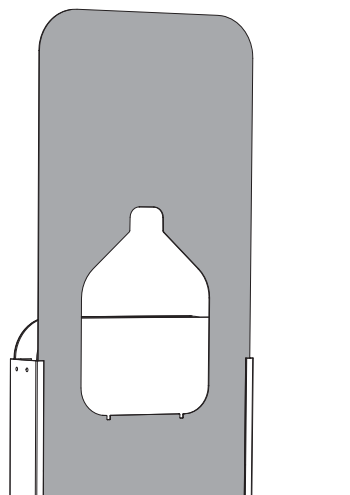

Fitting Panels

Finalising your water station. Last steps.

Installing the graphics panels is the last step to completing your water station installation. These polycarbonate, weather resistant coverings provide the finishing touch to your water station.

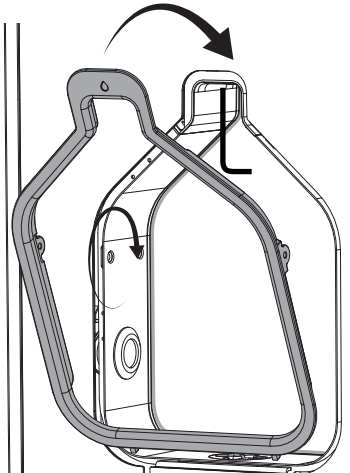
FITTING PANELS | REFILL STATION

Ensure you have completed all steps prior to fitting your graphic panels.

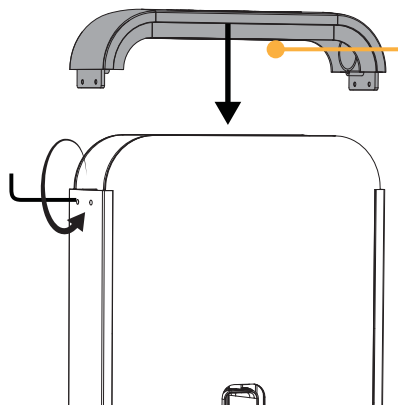
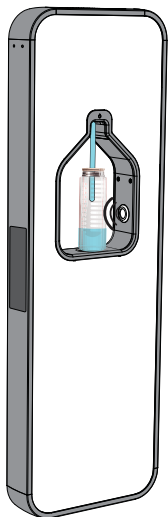
<p>1 Slide down to install the lighting backing panel.</p> 	<p>2 Slide down to install the front graphics panel.</p> 	<p>3   </p> <p>Fit the bottle refill surrounds.</p> 
<p>4   </p> <p>Attach top assembly including solar lighting module.</p>  <p>NOTE ENSURE YOUR LIGHTING IS ON AND SET UP</p>		<p>6 Test and enjoy! Set up is complete.</p> 



We highly recommend taking a photo of the completed water station.



FINISHED

FITTING PANELS | TALL KIT AND REFILL STATION

Only applicable for water stations fitted with a tall extension kit.

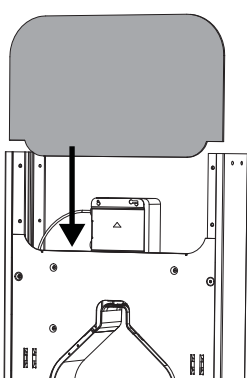

1 Slide down to fit all panels. *Only on ground mount model

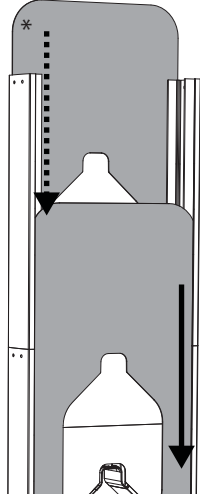

a)



b)

2  4mm Allen Key **3x** Screws  Clockwise

Fit the bottle refill surrounds.

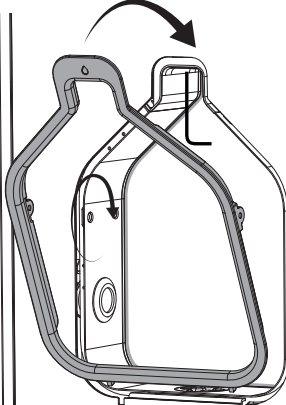

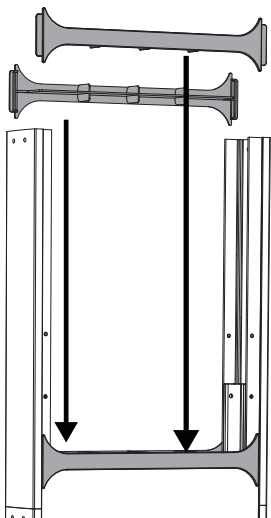

3 Slide down to fit 2x plastic dividers

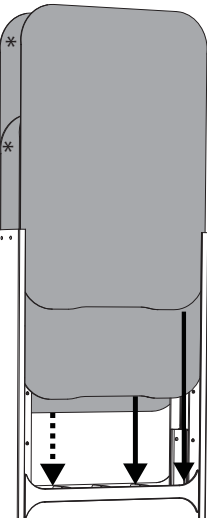

4 Slide down to fit 2x backing panels & 2x graphics panels



5  4mm Allen Key **4x** Screws  Anti-clockwise

Locate & screw fix solar lighting top.

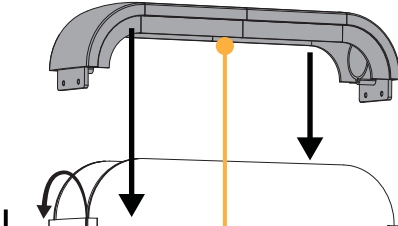



NOTE
ENSURE YOUR LIGHTING IS ON AND SET UP

6

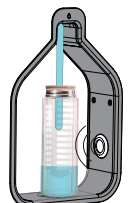
Test and enjoy!
Set up is complete.



 We highly recommend taking a photo of the completed water station.



FINISHED

Water station | Maintenance & Servicing

Wall Mounted Refill Station & Accessories

You have chosen to install a meetpat water station. These world leading water stations are manufactured with premium components and leave the factory carefully checked. To ensure the water station is functioning correctly and in perfect condition.

Please take time to familiarise yourself with our maintenance and servicing procedures ensuring the water station continues to function at the supplied high standard.

Exercising a common sense approach to maintaining your water station is recommended, given the water stations can be installed in numerous locations and varied weather conditions.





MAINTENANCE | OVERVIEW & SCHEDULING

Like with any publicly used resource, this water station may be subject to unexpected use or misuse. With this in mind we recommend a service and maintenance plan, as outlined in this booklet.

Along with the outlined service scheduling, we highly recommend;

- Regular visual checks to ensure no surface or part damage.
- Regular cleaning of edges and surfaces.
- Checking the water quality.
- Filter change regularly.

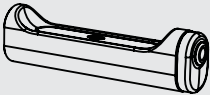
FAILURE TO COMPLETE ROUTINE MAINTENANCE AND SERVICING MAY VOID THE WARRANTY.

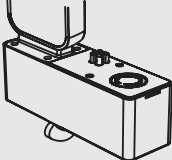
Product Parts	General (Weekly)	Detailed (12 Months or filter capacity)
 <p>PM-RS-03-GM</p>	<ul style="list-style-type: none"> - Clean nozzle - Clean drain grate - Surface wipe clean graphic panel - Check and clean sensor button - Surface wipe clean solar top 	<ul style="list-style-type: none"> - Replace water filter (if fitted) - Clean mesh filter - Battery change on valve battery pack - Remove graphics panels and clean dirt from frame
 <p>PM-RS-03-WM</p>	<ul style="list-style-type: none"> - Clean nozzle - Clean drain grate - Surface wipe clean graphic panel - Check and clean sensor button - Surface wipe clean solar top 	<ul style="list-style-type: none"> - Replace water filter (if fitted) - Clean mesh filter - Battery change on valve battery pack - Remove graphics panels and clean dirt from frame
 <p>PM-AK-01</p>	<ul style="list-style-type: none"> - Clean nozzle - Clean drain grate - Check and clean sensor button 	<ul style="list-style-type: none"> - Battery change on valve battery pack - Clean nozzle - Clean drain grate - Check sensor and function - Check bolts and connection
 <p>PM-TK-01</p>	<ul style="list-style-type: none"> - Surface wipe clean graphic panel - Surface wipe clean solar panel 	<ul style="list-style-type: none"> - A detailed service is not required for the Tall Extension Kit
 <p>PM-DB-02</p>	<ul style="list-style-type: none"> - Remove objects blocking the bowl - Clean surfaces - Check mechanism is functioning 	<ul style="list-style-type: none"> - Full pit clean - Check mechanism and tighten screws - Remove dog bowl and flush/clean pit

Need more help?

meetpat can help develop and conduct a maintenance program tailored to suit your water station fleet.

Please contact servicing team to find out more | service@meetpat.com.au

PANEL | REMOVAL & REPLACEMENT



IMPORTANT

ONLY REMOVE THE REQUIRED PANEL(S)
TO COMPLETE THE INTENDED TASK

**INTERNAL ACCESS IS ALWAYS FROM
THE FRONT OF THE WATER STATION**

REFERENCE THE SENSOR BUTTON

ACCESS FILTER & SHUT OFF TAP

STEP 1-3

BATTERY REPLACEMENT & FULL INTERNAL ACCESS

STEP 1-5

1

4mm Allen Key 3x Screws Anti-clockwise Remove Completely

Remove bottle refill surround.

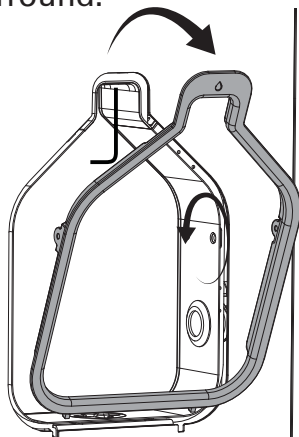

2

4mm Allen Key 4x Screws Clockwise Loosen Only DO NOT REMOVE

Remove solar lighting module.

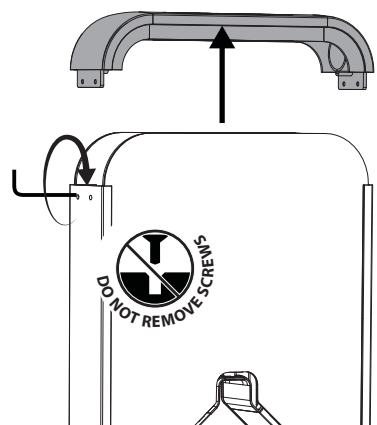

3

Remove the front graphics panel.

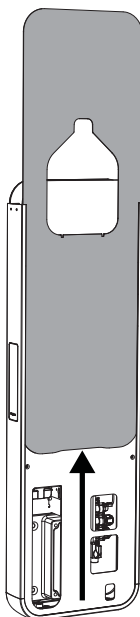

4

Remove the lighting backing panel.

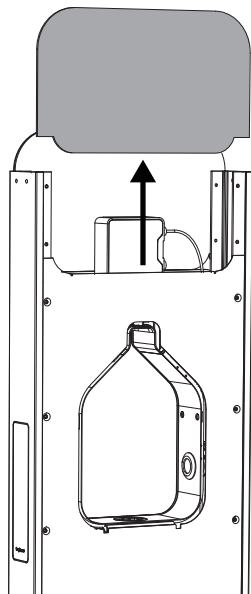

5

4mm Allen Key 8x Screws Anti-clockwise Remove Completely

Remove the access panel.

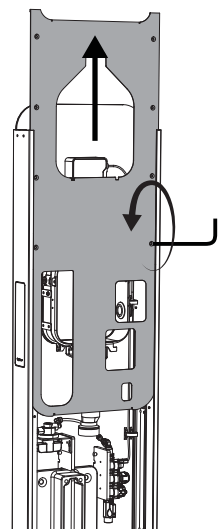

IMPORTANT

REATTACH ANY WATER PIPES
DISCONNECTED DURING DISASSEMBLY



FINISHED

REFIT PANEL(S)
FOLLOW STEPS IN REVERSE

FILTER | INSTALLATION & REPLACEMENT



ALWAYS TURN OFF WATER SUPPLY

DE-PRESSURISE THE WATER STATION BY ACTIVATING ALL SENSOR BUTTONS

1

Ensure the front graphics panel is removed. Refer panel removal

2 Locate the shut off valve. Turn off water supply.

3 Release all pressure from the water station.

Activate all the sensor buttons

4 Locate filter plug *or used filter if installed. Turn Clockwise to completely remove.

5 Install new filter. Turn Anti-clockwise to fit. Hand tighten.

6 Open valve to turn on water supply.



IMPORTANT

ACTIVATE ALL SENSOR BUTTONS TO FLUSH WATER & CHECK FOR LEAKS.

Refer troubleshooting to resolve any problems.

MESH FILTER | CLEAN & REPLACEMENT



ALWAYS TURN OFF WATER SUPPLY

DE-PRESSURISE THE WATER STATION BY ACTIVATING ALL SENSOR BUTTONS

1

Ensure the front graphics panel is removed. Refer panel removal

2 Locate the shut off valve turn off water supply.

3 Release all pressure from the water station.

Activate all the sensor buttons

4 To locate the Mesh Filter, unscrew and remove cap.

5 Run water over Mesh Filter to remove soils. Use a soft brush and gentle non-abrasive cleaner (if required).

6 Reinstall Mesh Filter and cap.

! Fit with washer end first.

7 Turn on the water supply.



ACTIVATE ALL SENSOR BUTTONS TO FLUSH WATER & CHECK FOR LEAKS.

Refer troubleshooting to resolve any problems.



IMPORTANT

REATTACH ANY WATER PIPES DISCONNECTED DURING DISASSEMBLY



FINISHED

REFIT PANEL(S)
FOLLOW STEPS IN REVERSE

SENSOR TAP | BATTERY REPLACEMENT

1 Remove front graphic panel only.
REFER PAGE 32

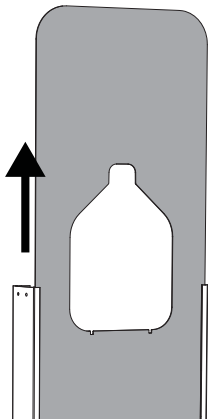

2 Locate the battery pack.

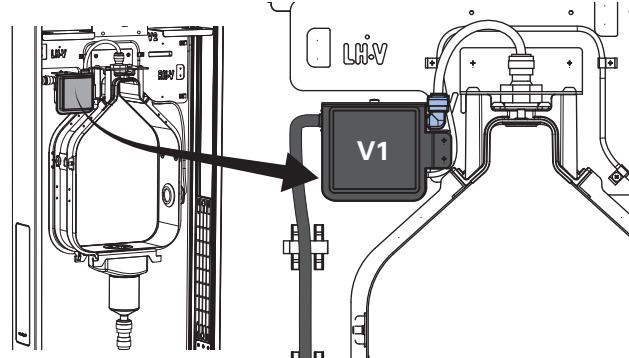

3 Detach and retain 4x screws and cover plate.

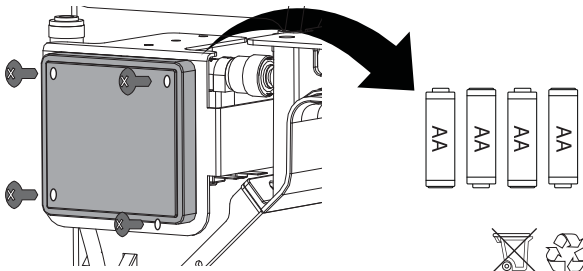

REMOVE AND DISCARD ALL OF 4X EXISTING BATTERIES RESPONSIBLY.

4 Install 4x new AA batteries and reattach cover.

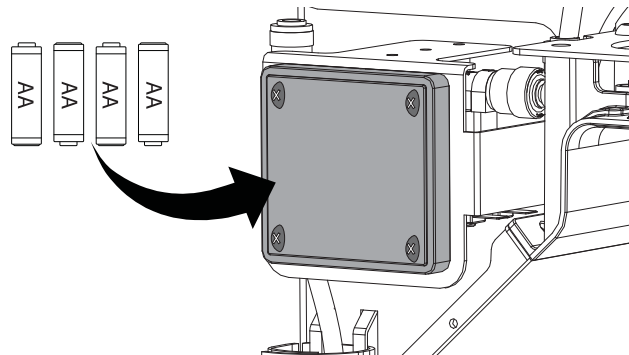

5 Test the sensor function.

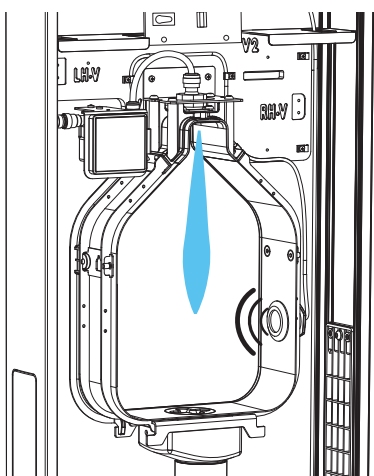

TROUBLESHOOTING



- Check all connections are plugged in
- Check polarity of batteries (+ / -)
- Check the valve is installed correctly (arrow indicates correct flow direction)
- Water is turned on
- Check batteries are charged and have sufficient voltage "not flat"
- Check for damage (broken, sticker, paint or dirt/debris) covering sensor button

FINISHED
REFIT THE FRONT PANEL
Page 32



STANDARD | CLEANING INSTRUCTIONS

QUICK CLEAN - WEEKLY (location dependant) meetpat recommended

DETAILED CLEAN - 12 MONTHS or filter capacity (whichever is first) meetpat recommended

1



Clean and wipe down all external surfaces. Use a non-acidic, non-abrasive cleaner and a soft brush (if required).

2

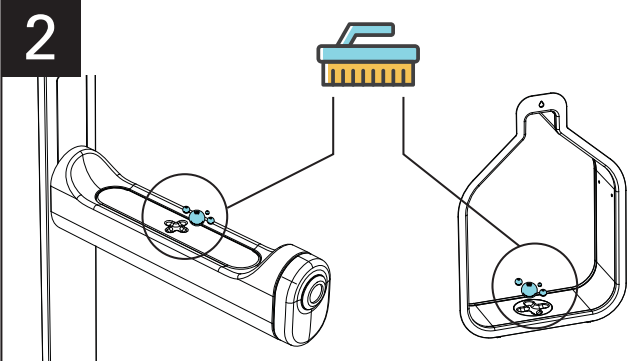

Use a soft (non-abrasive) scrubbing brush to clean the drain mesh. Ensure the mesh is free from any debris.

3



Check the nozzles for damage and/or blockages. Clean all nozzle surfaces with an antibacterial wipe.
*** Use a new wipe for each nozzle**

4

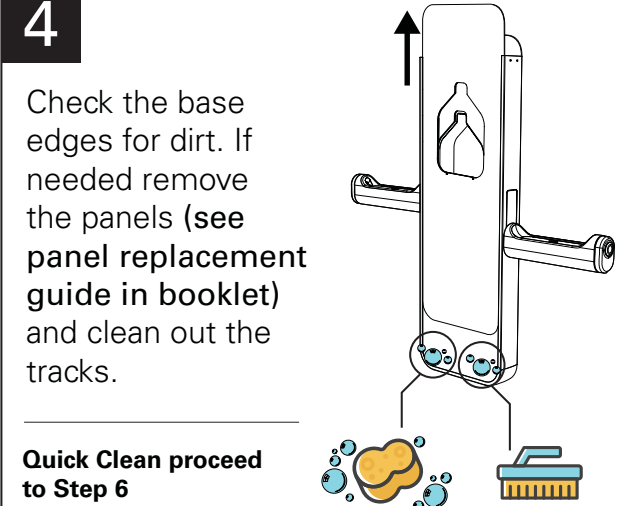

Check the base edges for dirt. If needed remove the panels (see panel replacement guide in booklet) and clean out the tracks.

Quick Clean proceed to Step 6

5 FLUSHING UNIT (Detailed clean only)

Flush out the internal lines with a meetpat line cleaning kit.

Contact meetpat to purchase a flushing cartridge (supplied complete with cleaning instructions)

 **REPLACE FILTER DURING DETAILED CLEAN**
 Refer Filter Installation Instructions

6

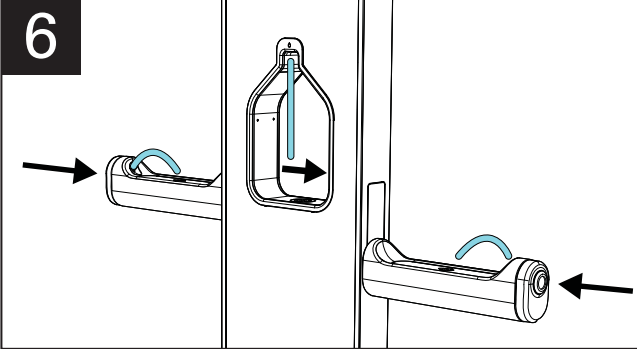

FINISHED

TEST FUNCTION OF ALL SENSOR BUTTONS
 CHECK FOR LEAKS
 CHECK WATER QUALITY & TASTE

TROUBLESHOOTING

1

Identify the Problem

Remove front panels to view the full function of the water station. This will help you correctly identify the fault, damage and/or leak.

2

Onsite Repair

Many problems can be easily fixed onsite by a qualified plumber.

- Removal of dirt/debris.
- Cleaning.
- Sensor battery replacement.
- Reconnect loose fittings.
- Install pressure reducing valve.

3

Further Steps

Other problems may require ordering of spare parts or further assistance from meetpat. When phoning through for additional support, staff will ask for the following information to correctly identify the product model/part.

- What is the serial number of the water station?
- Where is the water station located?
- Can you supply a photo/short video of the problem?
- Who purchased the water station?
- Can you supply a photo of the entire water station on location?

4

Contact meetpat

The service/sales team(s) will be able to assist you best in resolving the problem and/or ordering a replacement part.

sales@meetpat.com.au | service@meetpat.com.au | 026021 0300 | +6126021 0300

Some Common Questions

There is no water (or reduced water) when the sensor is activated?

Check the water is turned on, with adequate pressure and the hosing inside the water station is not bent or kinked. Check there are no blockages to the hosing or filter. Make sure the sensor batteries are not flat and the sensor is not covered with a sticker or object.

The water flow won't stop?

Check the water pressure is not too high. Check the sensor is not covered or dirty and the batteries are not flat.

The dog bowl won't return back up?

Check the gas strut is not broken. Review the dog bowl mechanism for any damage and check the connections are secure/not loose.

WARRANTY | MEETPAT POLICY

What is covered by this defects warranty policy?

meetpat warrants that new products purchased either from meetpat direct or through authorised distributors, which are still in the possession of the initial purchaser, will be free from defects for the warranty period, subject to the terms of this Policy.

A product may be defective if meetpat finds that it is non-conforming in material or workmanship and if the non-conformance materially impairs the performance of the product having regard to the purpose for which it was designed and the limitations stated below.

General product range.

Permanent Water stations – Three (3) Years

Portable Water stations – One (1) Years

Limited coverage warranty items.

For some special parts or components within a water station, warranty conditions are as below. For the complete limitations list, please see below.

Batteries – One (1) Year

LoRaWAN Electronic Monitoring Equipment – One (1) Year

Water Filters – One (1) Year

Graphics Panels - Three (3) Year Climate Dependant

Limitations.

This warranty will not cover products that:

- a) Include customer-specified materials or finishes that are not part of meetpat's standard product range at the time of manufacture;
- b) Are not installed and maintained as recommended in meetpat's written installation and maintenance guidelines; products are designed to operate within a minimum/maximum supply line pressure as indicated in the supporting instruction books. Any damage caused by reason of connecting a water cooler, bottle filler, fountain or packaged water cooler to supply line pressures outside of the working pressure is not covered by this warranty.
- c) Have not been used in accordance with any applicable usage guidelines;
- d) Have been misused or usage is in excess of normal wear and tear;
- e) Have been damaged for example as a result of collision, theft or vandalism; and/or
- f) Are manufactured by a third-party supplier and then resold by meetpat without incorporating any meetpat manufactured product into the third party product.

Finishes and components on meetpat products are updated periodically to respond to the demands and changing preferences of our customers. As a result we may discontinue some options before expiration of the Applicable Warranty Period and do not guarantee that any replacement product or part will be identical to, or match the finish of, the original.

Looking for help?

General enquiries/sales

sales@meetpat.com.au | +612 6021 0300

Faults and servicing

service@meetpat.com.au | +612 6021 0300

Spare parts

sales@meetpat.com.au | +612 6021 0300

meetpat®



meetpat products must be installed in accordance with the provisions of AS/NZS3500.1 and AS/NZS3500.2 and any relevant local regulations. Installations not complying with AS/NZS3500.1 and AS/NZS3500.2 may void the product and performance warranty provisions.

meetpat products are Watermarked WMTS105 to Australian standards and have brass free water system parts.

All recommendations within this document should be used as a guide only. Users and installers should seek suitable assistance to ensure units comply with all standards and are safe for use.

meetpat are constantly evolving and updating their products to ensure that they are designed and manufactured to the highest possible standard.

Please ensure you follow the supplied current guidelines when installing and servicing your water station.

For the most up to date copy of this Information Booklet, please visit meetpat.com.au

Meet Pat™ | Meet PAT Pty Ltd | meetpat.com.au

Phone: (02) 6021 0300, +612 6021 0300 Email: sales@meetpat.com.au
