

Portable Refill Station PT-RS-03

meetpat Product Range



Product Description

meetpat portable bottle refill station is suitable for both indoor and outdoor environments.

This water station is lightweight and is manufactured using stainless steel and powdercoated aluminium. With a lead free plumbing system and anti-bacterial bottle refill dispenser. Polycarbonate graphics panels with anti-graffiti protection. Non-refrigerated.

Suitable as a stand alone unit or interconnect multiple units with the joiner hose kit for larger events.

Product Specifications & Inclusions	
Tapware/ Touch Free Sensor	Infrared sensor with impact resistant lens. Located inside bottle refill window. 4x AA batteries. 100,000 activations (2-3 years for battery life)
Frame	304SS and aluminium (powdercoated)
Base	Rotational moulded HDPE
Nozzles	316SS stainless steel
Water Pressure	Max. 500kPa operating pressure (5 bar) Min. 120kPa operating pressure (1.2 bar)
Panel Finish	2mm clear unbranded polycarbonate
Flow Rate	4.5L per minute (pressure dependent)
Working Temp	1°C minimum 38°C maximum
Connectors	2x stainless steel 1/2" threaded connectors
Power	No electrical connection required
Warranty	1 year standard. Refer meetpat product warranty for full T&Cs.

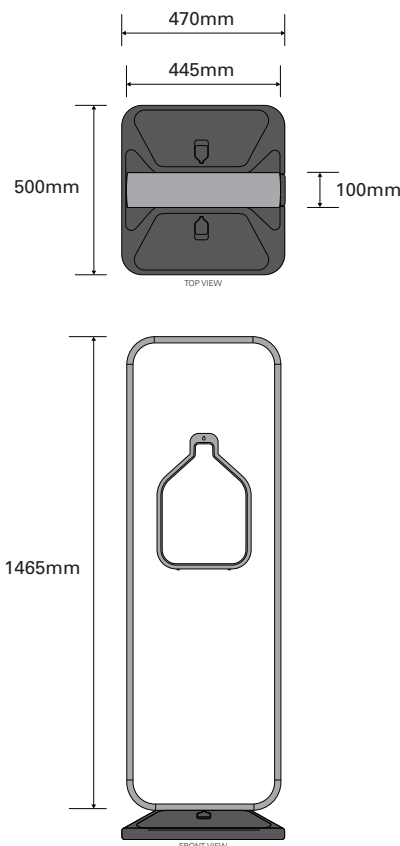

Accessories		
PTHK-01-WM	Drink Safe Hose Kit	10M drainage hose. 10M water supply hose. Tap adapters.
PTJK-01-WM	Joiner Hose Kit	Drainage and water supply to link multiple refill stations
PTCB-03	Portable Carry Bag	Nylon bag with shoulder strap & wheels. Water proof interior. Storage pockets.
AXFR-01	Water Filter	5 micron inline cartridge. Reduces bacteria. Improves taste. 22,000L capacity.
PTBK-01	Bolt Down Kit	HDPE with non slip surface. Bolt down fixings to regular portable base.
EXDM-01 Available 2024	Digital Water Meter Kit	E-Ink display. Inc flow meter and wiring.
TXLT-01-915	LoRaWAN Smart Water Meter Kit	Australia, USA, Asia 915/923MHz
TXLT-01-868	LoRaWAN Smart Water Meter Kit	Middle East, Europe 868MHz
EXCC-01 Available 2024	Core Controller Kit	Auto control module. Inc low temperature analysis, auto-flushing, freeze resistance and water quality monitoring.

Packaged Details		
Product	Weight	Packed Size*
PT-Refill Station	14.5kgs	150cm x 50cm x 13cm
PT-Base	4.7kgs	52cm x 50cm x 12.5cm
PT-Panels	3.2kgs	140cm x 44cm x 2cm

PT-RS-03 includes boxed: refill station, base & panels
*packed size varies depending on quantity and accessories ordered



Graphics & Printing for Panels (select option)	
Unbranded (no printing) Blank Graphics	No graphics printing supplied.
meetpat blue Standard Graphics	meetpat standard graphics. Printed and applied to panels.
Customised Printing Unique Graphics	meetpat assisted* personalised graphic design. Printed and applied to panels.

*graphics design service includes, design development and guidance, artwork proofs & two revisions

All information and images contained in the document are © Meet PAT™ - Meet PAT Pty Ltd or their respective owners. They are not be used without consent from Meet PAT™. As improvements in the design and performance of Meet PAT products are continuous, specifications may be subject to change without notice. This technical sheet is copyright and owned by Meet PAT™ - Meet PAT Pty Ltd ABN 48163544278. All rights are reserved. All products and sales are subject to Meet PAT™ terms and conditions.

Portable Refill Station PT-RS-03

meetpat Product Range



Product Overview

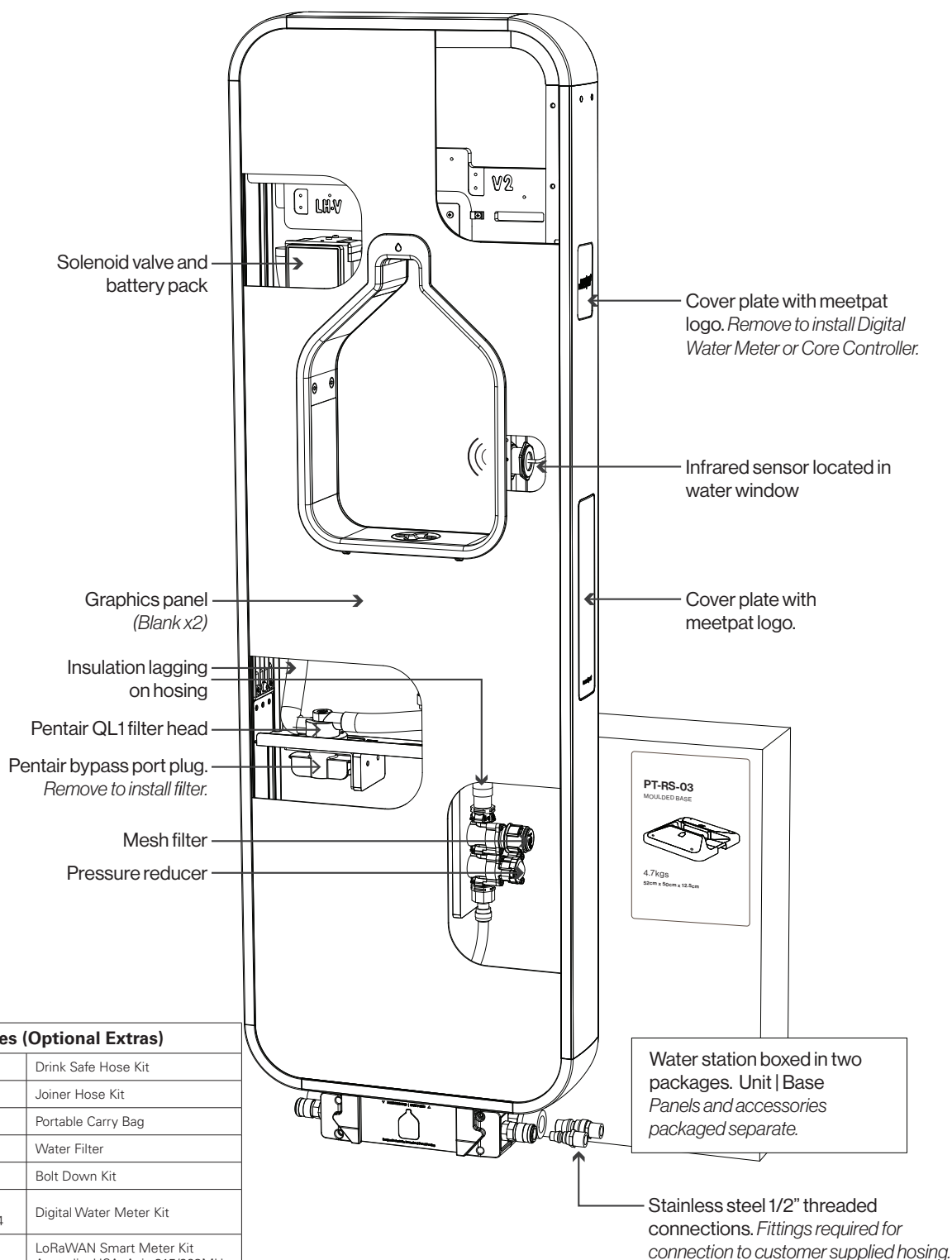

Accessories (Optional Extras)	
PTHK-01-WM	Drink Safe Hose Kit
PTJK-01-WM	Joiner Hose Kit
PTCB-03	Portable Carry Bag
AXFR-01	Water Filter
PTBK-01	Bolt Down Kit
EX-DM-01 Available 2024	Digital Water Meter Kit
TX-LT-01-915	LoRaWAN Smart Meter Kit Australia, USA, Asia 915/923MHz
TX-LT-01-868	LoRaWAN Smart Meter Kit Middle East, Europe 868MHz
EX-CC-01 Available 2024	Core Controller Kit

All information and images contained in the document are © Meet PAT™ - Meet PAT Pty Ltd or their respective owners. They are not be used without consent from Meet PAT™. As improvements in the design and performance of Meet PAT products are continuous, specifications may be subject to change without notice. This technical sheet is copyright and owned by Meet PAT™ - Meet PAT Pty Ltd ABN 48163544278. All rights are reserved. All products and sales are subject to Meet PAT™ terms and conditions.

Hose Kit PT-HK-01-WM

meetpat Accessories

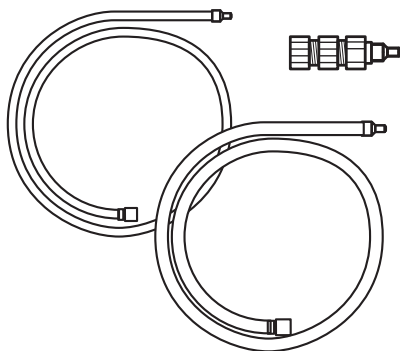

Product Description

An easy to fit, safe water hose kit, adds reliable connection and drainage for the portable and semi-portable refill stations.

The kit comes complete with; 1x water supply hosing, 1x drainage hosing and 2x tap adapters (AUS / US). The kit enables a single water station set up, to suitable water inlet and outlet hosing to drainage point.

Compatible with PT-RS-03 & XS-RS-03-TM

All kit parts can pack easily into the portable carry bag (purchased separately).

Product Specifications & Inclusions	
Hose Material	Non-toxic. Food grade poly-olefin.
Tap Adaptor	Stainless Steel 1" Threaded Adapter 3/4" Threaded Adapter 3/4"US GHT Threaded Adapter
Hose Size	10 meter water supply hose 10 meter drainage hose
Fixings	23mm Female water supply connection 35mm Drainage connection
Assembly	Quick connect barb fitting
Warranty	1 year standard. Refer meetpat product warranty for full T&Cs.
Replacement	Available from meetpat. Reorder code: PT-HK-01-WM

Packaged Details		
Product	Weight	Packed Size*
PT-HK-01-WM	2.9kg	52cm x 50cm x 12.5cm

*packed size varies depending on quantity and accessories ordered

All information and images contained in the document are © Meet PAT™ - Meet PAT Pty Ltd or their respective owners. They are not be used without consent from Meet PAT™. As improvements in the design and performance of Meet PAT products are continuous, specifications may be subject to change without notice. This technical sheet is copyright and owned by Meet PAT™ - Meet PAT Pty Ltd ABN 48163544278. All rights are reserved. All products and sales are subject to Meet PAT™ terms and conditions.

**Meet Pat™ | Meet PAT Pty Ltd | meetpat.com.au
(02) 6021 0300, +612 6021 0300 | sales@meetpat.com.au**

meetpat®

Joiner Hose Kit PT-JK-01-WM

meetpat Accessories

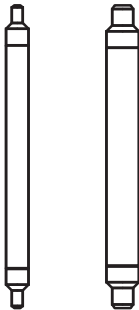

Product Description

The quick connection, joiner hose kit, adds a reliable attachment between multiple refill stations. Creating a wall or bank of products for additional refill outlets at a single location.

Compatible with PT-RS-03 & XS-RS-03-TM

The kit comes complete with; 2x joiner hose, enabling the connection of two refill stations. All additional refill stations require multiple kits to be purchased.

All kit parts can pack easily into the portable carry bag (purchased separately).

Product Specifications & Inclusions	
Hose Material	Non-toxic. Food grade poly-olefin.
Connector Material	Stainless steel
Joiner Size	360mm
Fixings	23mm Female water supply connection 35mm Drainage connection
Assembly	Quick connect barb fitting
Warranty	1 year standard. Refer meetpat product warranty for full T&Cs.
Replacement	Available from meetpat. Reorder code: PT-JK-01-WM

Packaged Details		
Product	Weight	Packed Size*
PT-JK-01-WM	500gm	40cm x 10cm x 10cm

*packed size varies depending on quantity and accessories ordered

All information and images contained in the document are © Meet PAT™ - Meet PAT Pty Ltd or their respective owners. They are not be used without consent from Meet PAT™. As improvements in the design and performance of Meet PAT products are continuous, specifications may be subject to change without notice. This technical sheet is copyright and owned by Meet PAT™ - Meet PAT Pty Ltd ABN 48163544278. All rights are reserved. All products and sales are subject to Meet PAT™ terms and conditions.

**Meet Pat™ | Meet PAT Pty Ltd | meetpat.com.au
(02) 6021 0300, +612 6021 0300 | sales@meetpat.com.au**

meetpat®

Bolt Down Kit PT-BK-01

meetpat Accessories

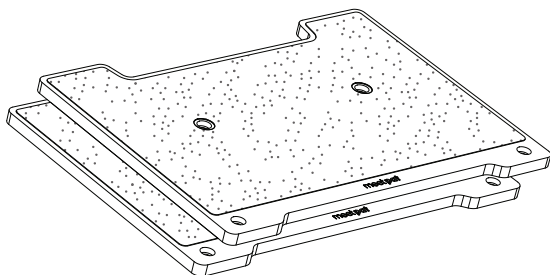

Product Description

An easy to fit, heavy duty bolt down kit, consisting of 2 ramps. Providing additional stability to the portable refill station. Individual platforms with a non-slip top surface are simply fitted to the top of a portable base. This system can quickly be added or removed from your event set up, with easy hand tighten recessed bolts.

Compatible with PT-RS-03

Especially effective in high wind locations or where regulations call for a larger base footprint.

Product Specifications & Inclusions	
Body Material	HDPE
Outer Top	Textured, slip resistant
Colour	Black
Finished Size	49cm x 68.5cm x 2cm per ramp
Fixings	4x Bolts (supplied with PT-RS-03)
Assembly	8mm Allen Key
Warranty	1 year standard. Refer meetpat product warranty for full T&Cs.
Replacement	Available from meetpat. Reorder code: PT-BK-01

Packaged Details		
Product	Weight	Packed Size*
PT-BK-01	12.5kg	50cm x 70cm x 5cm

*packed size varies depending on quantity and accessories ordered

All information and images contained in the document are © Meet PAT™ - Meet PAT Pty Ltd or their respective owners. They are not to be used without consent from Meet PAT™. As improvements in the design and performance of Meet PAT products are continuous, specifications may be subject to change without notice. This technical sheet is copyright and owned by Meet PAT™ - Meet PAT Pty Ltd ABN 48163544278. All rights are reserved. All products and sales are subject to Meet PAT™ terms and conditions.

Meet Pat™ | Meet PAT Pty Ltd | meetpat.com.au
(02) 6021 0300, +612 6021 0300 | sales@meetpat.com.au

meetpat®

Portable Carry Bag PT-CB-03

meetpat Accessories

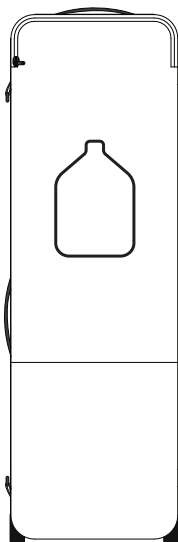

Product Description

A versatile nylon carry bag. Can be either carried using the shoulder strap, handle or wheeled over sealed surfaces

Purposely designed and manufactured to easily fit; the portable refill station, moulded base and hosing.

Includes; removable shoulder strap, 2 way zipper opening and additional internal mesh pocket.

Product Specifications & Inclusions	
Outer Material	Nylon Oxford
Lining	Poly tarpaulin (water proof)
Colour	Black and grey
Opening	2 way zipper and velcro pockets
Finished Size	152cm x 49cm x 22cm
Warranty	1 year standard. Refer meetpat product warranty for full T&Cs.
Replacement	Available from meetpat. Reorder code: PT-CB-03

Packaged Details		
Product	Weight	Packed Size*
PT-CB-03	5.5kgs	60cm x 50cm x 26cm

*packed size varies depending on quantity and accessories ordered

All information and images contained in the document are © Meet PAT™ - Meet PAT Pty Ltd or their respective owners. They are not be used without consent from Meet PAT™. As improvements in the design and performance of Meet PAT products are continuous, specifications may be subject to change without notice. This technical sheet is copyright and owned by Meet PAT™ - Meet PAT Pty Ltd ABN 48163544278. All rights are reserved. All products and sales are subject to Meet PAT™ terms and conditions.

**Meet Pat™ | Meet PAT Pty Ltd | meetpat.com.au
(02) 6021 0300, +612 6021 0300 | sales@meetpat.com.au**

meetpat®

Water Filter AX-FR-01

meetpat accessories

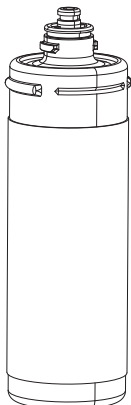

Product Description

Water filter is compatible with both permanent and portable refill stations.

Product effectively filters dirt and particles as small as 5 microns. Inhibits the growth of bacteria, reduces chlorine taste and odour and improves the taste of the water.

Compatible with
PT-RS-03 & XS-RS-03-TM & PM-RS-03 (GM & WM)

Product Specifications & Inclusions	
Rated Capacity	22,000 litres
Flow Rate	3L per minute (pressure dependent)
Working Temp	1°C minimum 38°C maximum
Service Flow Rate	5.67 Lpm
Connections	Hand fit to water station. No tools required.
Power	No electrical connection required
Warranty	1 year standard. Refer meetpat product warranty for full T&Cs.
Replacement	Available from meetpat. Reorder code: AX-FR-01

Packaged Details		
Product	Weight	Packed Size*
AX-FR-01	550gm	27cm x 10cm x 10cm

*packed size varies depending on quantity and accessories ordered

All information and images contained in the document are © Meet PAT™ - Meet PAT Pty Ltd or their respective owners. They are not to be used without consent from Meet PAT™. As improvements in the design and performance of Meet PAT products are continuous, specifications may be subject to change without notice. This technical sheet is copyright and owned by Meet PAT™ - Meet PAT Pty Ltd ABN 48163544278. All rights are reserved. All products and sales are subject to Meet PAT™ terms and conditions.

**Meet Pat™ | Meet PAT Pty Ltd | meetpat.com.au
(02) 6021 0300, +612 6021 0300 | sales@meetpat.com.au**

meetpat®